

CSA Rating Rule 2023- Measurer's Guide

January 2023

1. Measurer's Requirements and Obligations

- 1.1. At present measurers do not pay an annual registration fee to the CSA, but the CSA officers may change this in the future and charge a membership fee in accordance with CSA bylaw 6.2.
- 1.2. According to the CSA bylaw 18, the measurers group can appoint a delegate to CSA meetings.
- 1.3. A Measurer is not restricted from joining CSA as an individual member or from participating in the CSA as a representative of a sailing organization. Measurers may also serve as CSA officers if selected.
- 1.4. Measurers shall be entitled to charge reasonable fees for their services.
- 1.5. Measurers shall adhere to the following guidelines –

A Measurer shall promote the principle of "a level playing field" to the sailing public at large in respect of the Caribbean Rating Rule. A Measurer shall not be an advocate for the improvement of the rating of a boat on which he or she is sailing or has close business ties with. A Measurer shall not measure the boat that he or she is sailing on unless it is determined by and approved by the CM that it is impractical for any other measurer to do so. Any such self-measurement shall be highlighted in the database. A Measurer shall not act as a paid professional consultant to yachts racing under the CSA Rule in respect of handicapping issues.

- 1.6. A Measurer will be removed from the list of measurers if he or she has not paid any fee due to the CSA within 3 months of a final request to do so, or If, in the opinion of the CSA Rating Committee (CSA bylaw 16), that measurer has violated the provisions of this measurer's guide, or is not carrying out their duties with the appropriate accuracy and care, or is bringing disrepute to the CSA rating rule, or If, in the opinion of the CSA Officers, Art 3.5 of the CSA bylaws needs to be invoked.

Before expelling a measurer from the CSA and removing that measurer from the list of measurers the procedure outlined in bylaw 3.6 will be followed.

2. Certificates

- 2.1. The rating certificate issued to a yacht shall be valid for one calendar year. Rating certificates are validated by measurers using the online rating program. Each valid certificate has a digitally generated unique authorization number. Only such digitally authorized certificates are considered valid.
- 2.2. A yacht may only be issued with three certificates per calendar year. To clarify, this means the yacht can make up to two changes to their configuration with no charge. For example, changing their asymmetrical spinnaker from a fractional to a masthead sail counts as one of the three certificates.
- 2.3. A yacht's certificate becomes invalid when:
 1. The period of validity expires or the Rating Rule is changed.
 2. The ownership of the yacht is changed.
 3. The Authoritative Body so decides.
 4. A modification to a yacht's hull or rig affecting her parameters is made.
 5. New sail(s) are delivered to the yacht.
 6. Repairs are made to the yacht's structure, rig, accommodation or equipment arrangements such as to affect measurably the yacht's parameters.

3. **Computations** - These are made by the Rating Rule Software from the information supplied by the measurer who shall take care that this information correct. The measurer must check both the entries and the final TCF's obtained against similar yachts in the database, where possible, to ensure that the resulting Rating is reasonable and sensible.

4. Measurements - General

- 4.1. It is important to communicate to the owner (owner in this guide is used interchangeably with skipper, owner's representative, etc. -- basically the person authorized to make decisions) that the boat is in the correct condition for measurement. This means anything that will not be on board while racing is off the boat. When first communicating with the owner, be sure to emphasize this to avoid surprises on measurement day. Typically the cruising anchor and rode will not be left on board for racing. Be sure it and any other gear that will not be on board is off. Personal gear of the crew should be off. Excess tools and spares should be off. Excess sails should be removed. In the end the more a boat tends to the cruiser racer and full cruiser end of the spectrum, the harder this will be. Explain anything on board when measured must be on board when racing. Encourage owners to strip as much gear off as practical. This gives them the most freedom during regattas.
- 4.2. **Hull measurements** shall be taken directly from the hull proper except where particularly specified. No projections such as rubbing strakes, chocks, boomkins or other protuberances shall be included in the measurements.
- 4.3. **Hollows and Projections** - e.g. Bumps and similar. The most likely occasion this will be encountered is measuring an older boat designed to the IOR Rule. Where hollows or projections or other deviations from the fair surface of the hull or its appendages occur in the position of a point of measurement, the measurer shall, if practical, adjust the measurement by relating it to the fair surface of the hull or appendage. If, in the measurer's opinion the fair surface of the hull has been intentionally altered (i.e. "bumped") in order to obtain a more favorable measurement (so as to artificially lower the yacht's TCF), then the measurer shall note this on the measurement form and refer the matter to the CM who will be entitled to take any action they see fit which may include increasing the yacht's rating.
- 4.4. **Units of Measure** - Metric dimensions will be used for measurement. Hull dimensions will be taken to the nearest millimeter. Sail and rig dimensions will be taken to the nearest centimeter.
- 4.5. **Measurement Conditions** - Measurement shall only be carried out in wind and water conditions sufficiently calm to permit an accuracy of +/- .002 points of TCF.
- 4.6. **Bendy Rigs** – The measurer shall measure the rig with the mast as near as is practical to the straight configuration. Backstay tension shall be adjusted to hold the rig firm so as to allow accurate foretriangle measurements to be taken.
- 4.7. **Masts movable at deck** – Where a mast is readily moveable at deck, measurements shall be taken with the mast in its furthest aft position. For masts that have hydraulic or other devices for tensioning the rig, the mast shall be set-up in such a way that all the standing rigging is taut and the mast is held in place.
- 4.8. **Waterplane Measurements** – The water plane is the plane where the hull intersects the water surface. For all overhang and freeboard measurements there shall be no persons aboard the yacht. Mooring and docking lines shall be slack during measurement so as not to influence these waterplane measurements.
- 4.9. **Lifelines**. Hiking is a rating issue, but lifelines are not. We do not require lifelines for rating purposes but when they are fitted they have to comply with ISAF Rule 49.2. For allowed crew positions with single lifelines see ISAF Case 36.

Boats not fitted with lifelines from original design shall be considered as stanchions outboard.

5. Individual Hull Measurements

- 5.1. Please see the figures at the end of this guide for a diagram demonstrating the measurements.
- 5.2. **Length Overall “LOA”** - The length overall “LOA” shall be measured on the centerline of the yacht and is the horizontal distance in profile between the forward and after terminations of the hull proper. Measurements shall include the rail (bulwark or toerail) only and if such rail forms a continuation of the external surface of the hull. Any projection, which in the opinion of the measurer extends the sailing lines of the hull, shall be included in the LOA measurement. Rudders shall not be included in length measurements. The term “rudder” shall be taken to also include any parts attached to the rudder and rotating with it. Any part of a fixed fairing piece between the top of the rudder proper and the hull proper and located aft of the rudder post shall be considered as a part of the rudder, and thus NOT included in hull length measurement provided such fairing piece does not exceed the maximum thickness of the rudder.
- Note:** The method of measurement stipulates that LOA is in fact derived from the summation of LOAa – the length from the forwardmost point of the hull proper to the forward face of the mast at deck level plus LOAb – the length of the aftermost point of the hull proper to the same forward face of the mast at deck level. **CSA instructs measurers to measure accordingly because LOAa is used in the calculations.**
- 5.3. **Length Waterline “LWL”** – This is the length along the floating, as measured waterline of the boat. It is determined subtracting the forward (**FOH**) and aft (**AOH**) overhangs from the LOA.
- 5.4. **Forward Overhang “FOH”** – The distance along the waterplane from a plumb bob dropped from the same point used to measure **LOAa** to the intersection of the stem with the waterplane. This is usually measured with a floating metre stick or similar. This measurement can be tricky with a boat floating such that the forward knuckle is above the waterplane.
- 5.5. **Aft Overhang “AOH”** – The distance along the waterplane from a plumb bob dropped from the aft most point of the boat, the location used to determine **LOAb** and the intersection of the hull with the waterplane. Also tricky with modern boats with a shallow run.
- 5.6. **Midsection M1** - M1 shall be the vertical cross section of the yacht which falls at a distance of 0.55 x LWL aft of the forward termination of the waterplane. This becomes the principal station for the measurements detailed below. **It is critical that this position be correct as it affects several measurements.** To locate this point on deck typically the length of the FOH is added to the M1 distance. Then LOAa is subtracted from that distance to arrive at the location aft of the forward face of the mast to locate M1 on deck.

5.7. Beams - B55, Bmax, Bwl

B55 - The yacht’s beam - is measured at M1. B55 is the widest width of the hull proper, **wherever it occurs vertically**. The measurement so obtained will not necessarily be the maximum beam of the yacht. With most modern boats the maximum beam will be at deck level, but some older IOR boats will have tumblehome where the maximum beam at that longitudinal location occurs somewhere down the topsides. Newer race boats frequently have a large deck radius; in this case the B55 measurement will be at the intersection of the radius and the topsides. The easiest way to measure this is with a plumb bob.

BMax – Maximum Beam. This is measured only when there are extensions to the deck or hull proper – such as wings, seats, outriggers, or widened flared shear – to allow the crew to be carried outboard of the normal hull; the maximum beam over these extensions, **wherever it occurs**, shall be measured and entered in the rating programme as BMax. **Note:** the natural widest beam of the FAIR hull of the yacht may be greater than B55 above. It is not the intention of the RULE to include this in the B Max entry in the rating calculations.

Bwl - Beam at waterline. This is the width of the hull at waterplane level, measured at M1. Bwl is measured as an inboard offset from the measured beam B55. **There is a high possibility this measurement will be used in the future in the calculations. To measure this, leave the plumb bobs used to measure B55 hanging and measure inboard with a floating metre stick.**

5.8. **Quarter Beam Depth - D55.** This measurement is taken at M1. “d” is the vertical distance from the deck level (of the hull proper, projected as necessary and ignoring any discontinuities at the hull/deck junction), to a point on the underwater surface of the hull which is at one quarter of the B55 measurement outboard from the centerline of the hull. It is taken, using a special “square” tool both sides and each measurement is entered in the database. See figure XYZ

5.9. Freeboards – F55, Ff

Ff - Freeboard Forward. This is the vertical distance from the forward termination of LOA to the waterplane. If a bulwark is present, measure to the top of the bulwark.

F55 - Freeboard Midships. This measurement is taken at M1 station. “Fm” is the vertical distance from the level of the deck (**the same level as used in the “d” measurement**) to the water plane. Measurements are taken on both sides, and each measurement is entered in the database. Frequently with a yacht with a large deck radius a batten is required to project the fair extension of the deck. ORC measures the location differently and uses a point closer to the midpoint of the radius, at a 45 degree tangent line. Remember this when comparing ORC measurements to CSA measurements. Any variation from using the intersection of the deck (extended) and topsides should either be noted in the notes to measurers section of that boat’s certificates. This will reduce confusion if someone else checks the boat later. Alternatively, correct the measurements before entering; even then, it is best to note it.

5.10. Drafts - V, Vmax, Vmin

Vmax - fixed draft. This is the maximum draft to the lowest point of a fixed keel (or rudder if deeper), or to the lowest point of a moveable ballasted keel or centerboard in its fully lowered position, whichever is the greater. At this time verify that the keel has not been modified. Very rarely a boat will come through with a keel with a trim tab fitted. Be sure to note this in the notes to measurers. **Note:** There may be instances for certain classes where a ballasted keel is left fixed, permanently up or permanently down, and cannot be adjusted during racing. This type of keel is considered a fixed keel. A Melges 32 or 24 is a good example of this type of boat. In such cases Vmax is the draft to the lowest point of this keel in its fixed position (or lowest point of the rudder if this is lower).

Vmin – minimum draft. This is the draft of a yacht with a moveable appendage – ballasted keel, centerboard or similar - when this moveable appendage is in the fully raised position. If a measurer is in doubt they should take advice from the Chief Measurer.

Vmax and Vmin will generally be taken from a yacht’s plans or other reliable descriptive literature. If Vmax and Vmin cannot be reliably established in this way, then the dimension must be physically measured in the water. **Note:** – some boat designs will have a variety of keel options. The measurer must ensure they are using the correct keel option for the boat in question. Sales brochures and Lloyds registration papers are often inaccurate. Frequently a charter version of a production boat will have a draft that does not correspond to any of the standard options for the production version.

5.11. **Engine Distance ED** - The Engine Distance is the horizontal distance from M1 to a vertical transverse plane through a point midway between the furthest forward and the furthest aft engine mounts. (Gearboxes are included as a part of the engine proper if directly coupled to it.)

5.12. **Canting Ballast** - Boats with canting ballast (keels) will have this feature noted in the database and will be assessed appropriate keel and rudder factors by the CM. The angle of cant in degrees from off centerline must be recorded in the measurer’s notes.

5.13. **Canards and Daggerboards** - These could be either fore/aft symmetrical type or twin athwartships asymmetrical type. The presence of Canards and Daggerboards and of which type must be recorded in the measurer’s notes section.

5.14. There are currently three basic types of keel. These are fixed, centerboard, and CBTF (canting ballast twin foils). Check the appropriate style. Rarely you will measure a boat with a canting keel and one centerline daggerboard. This boat will also be considered a CBTF style of keel.

6. Sails - General

6.1. **Definitions** – Sail **Definitions** will comply with the World Sailing “Equipment Rules for Sailing” unless stated hereunder. For measurement the terms “Head”, “Tack” and “Clew” shall be defined as the intersection point of the relevant adjacent edges of the sail, produced as necessary.

6.2. **Procedure for Measuring of Sails** – When dimensions are to be measured off the sails themselves, the sail shall be laid flat on a plane surface and stretched tight by hand to remove wrinkles across the line of measurement so as to include the full fabric length between measurement points. The foot dimension of any sail shall be the straight-line distance from tack to clew. Specific details for measuring specific sails are given below. The weblink to the current Equipment Rules of Sailing is:

<https://www.sailing.org/inside-world-sailing/rules-regulations/equipment-rules-of-sailing/> Downloading and printing out the relevant pages of Section G, definitions of sail measurements, is a good reference.

The ORC sail measurement guide is located here: <http://www.orc.org/index.asp?id=17> It includes a You Tube video of how to measure sails. The ORC takes the ¼ width measurement of headsails and mainsails.

The IRC measurement guide at <https://ircrating.org/wp-content/uploads/2022/11/IRC-Measurement-Manual-2023.pdf> is useful for interpreting the measurements off an IRC certificate.

Useful YouTube links for the three types of sails:

Mainsail: <https://www.youtube.com/watch?v=q8sRus-h0c>

Headsails: https://www.youtube.com/watch?v=_KaIj7MAjag

Spinnakers: <https://www.youtube.com/watch?v=GL6UHyoQHW0M>

6.3. Sail Materials Classification

(i) Lo-Tech. Any sail that is BOTH crosscut design AND made from a polyester type material with no membrane. Some cross cut sails look like regular dacron but are not. If in doubt check with the sailmaker or the Chief Measurer or Technical Officer

(ii) Hi-Tech. Any sail other than above.

6.4. **Spinnakers – Definitions** A spinnaker is any sail set forward of the foremost mast where the halfwidth (mid leech to mid luff) of the sail exceeds 75% of the length of the foot. Code 0's and similar need to be checked to confirm whether they rate as a headsail or an asymmetrical spinnaker

6.4.1. **Symmetrical Spinnakers** – Spinnakers where the difference between the luff length and the leech length is less than 2% of the shorter dimension.

6.4.2. **Asymmetrical Spinnakers** – Spinnakers where the lengths of the luff and leech do not comply with above.

6.4.3. **Unusual Downwind Sails** – Downwind sails which do not fit either the above definition of a spinnaker or of a headsail or which do not comply with other World Sailing ‘Equipment Rules for Sailing’ shall **not** be used. e.g. Kite sails, Parasails, and Spinnakers with modified elements of kites and/or parasails.

6.4.4. **No Battens in spinnakers** - Battens are **not allowed** to be used in spinnakers. Any material added to support or stiffen a spinnaker will make it a headsail, regardless of the dimensions.

6.5. **Headsails – Definitions** A Headsail is any sail set forward of the foremost mast which does **not** comply with the criteria of a Spinnaker as described above and shall be subject to the following:

6.5.1. **Foot Drop** – The fabric length of the sail between the midpoint of the foot and the midpoint of the luff shall not exceed 0.55 of the length of the leech. (Measured as a straight-line distance between head and clew). Contact the CM if this dimension is exceeded.

6.5.2. **Second Headsails** - A yacht may carry two headsails at any time. Any headsail carried downwind in addition to its rated headsail must fall within the definition of a jib as above and must not have a larger area than the declared headsail.

6.5.3. **Lower rating with smaller headsail** - All yachts are allowed two different sized headsails. The measurements of both will be included in the database and used to calculate a TCF for the yacht with the appropriate headsail. The yacht may be entered in a regatta with either headsail and with the corresponding TCF. However, if so elected, then no larger headsail than the one declared may be used at that regatta. Remind competitors of this when they choose the smaller headsail that if they blow it up they may not change to the larger headsail rating in the middle of the regatta. This **will** happen to you if you are a regatta measurer.

6.5.4. **Staysail and cutter rigs** - If a yacht has a staysail cutter type rig then the measured LP shall be taken from the clew of the sail which falls further aft of the forestay. Note: If the clew of the staysail is aft of the rated working jib or genoa, the LP for this sail combination becomes the perpendicular distance from this staysail clew to the headstay.

- 6.6. **Spinnaker and Bow Poles.** Yachts may choose to rate with either –
- a) symmetrical spinnaker only
 - b) asymmetrical spinnaker only
 - c) both of above
 - d) no spinnaker

The rating programme will adjust the TCF accordingly. Be sure to explain to the boat representative that the spinnaker configuration is not the same as the two headsail option. The boat representative must choose a, b, or c for the spinnaker configuration that will be used to calculate the TCF. If the owner wants to change the spinnaker configuration between regattas they may do so, and it will count as one of the three certificates allowed in a year. By default the program calculates jib and main only, so d is always an option. Remind the boat owner of this and encourage them that if they have a spinnaker have the spinnaker entered into the database even if they normally race jib and main.

6.6.1. **Yachts which choose a) above** - can tack the sail at the end of an articulating spinnaker pole. Measure the spinnaker pole length and enter this in the database. Refer to the IRC measuring guide to be sure the pole is measured correctly.

6.6.2. **Yachts which choose b) or c) above** - can tack the sail on either an articulating spinnaker pole or a fixed (or retractable) bow pole, or articulating bow pole, or a fixed tack point on deck. The yacht must declare during measurement which choice of tack position she elects to make. The **tack distance** (See later for definition) is then measured and recorded in the database, as is the spinnaker pole length (with option c).

6.6.3. **Yachts which choose c) above** - must measure the largest symmetrical spinnaker and the largest asymmetrical which they carry.

6.6.4. **Yachts which choose d) above.** Articulating spinnaker poles or whisker poles, attached to the mast, may be used to boom out a headsail when sailing downwind but this must be included in the yacht's parameters in the database. This pole length (see later for definition) must be measured and recorded.

6.6.5. **Wishbone or Gary Hoyt arrangements** - Headsails fitted with a stiff full-length bottom batten, a wishbone arrangement, a Gary Hoyt spar, or similar arrangement are rated as using a spinnaker pole and will be rated accordingly. **Use tick box: "Jib boom/camber spar" in the "sails" data entry box.**

6.7. **Sail Area Calculations** – The Rating Programme will compute the sail area from the data supplied. This may include using any cross width or any other measurements deemed necessary. Where a boat has in-mast or in-boom mainsail roller furler this will be recorded on the yacht's parameters in the data base, and the Rating Programme may adjust the Yacht's TCF accordingly.

6.8. **Add Sail**- This feature is under the yacht drop down menu at the upper right of the web page. Click on yacht then click add sail to add a sail to the database of that boat. This feature is very helpful for a boat with a large sail inventory (the Volvo 70's and 65's are typical boats) that might change their certificate once or twice in a season. Create a name unique to the sail and input the standard sail measurements for the type of sail selected. Once the sail is saved it will be listed under the sail section on the input web page. Another use for this feature is when a boat owner wants to know how much their rating will change if they add a new sail to their inventory, for example changing from a

100% jib to a 110% jib. Create a new jib with add sail. Use the provided measurements of the proposed sail, save it then select that sail. Check the new rating number and then the owner can decide if it is worth making the change.

6.9. Mainsail Measurements

- 6.9.1. **PM** - is the distance from the highest hoist of the main halyard to the level at which the top of boom intersects with the mast. Note: CSA measures PM as the hoist of the halyard and ignores any black (or white) band which may be fitted at the top of the mast. Be sure to correct for any stops or elongated knots on the halyard so that PM is what the maximum hoist would be without such stops, knots etc. CSA does not use Mainsail Luff Length to compute MSA (mainsail area) but uses Pm as above.
- 6.9.2. **EM** - is the distance from the back of the mast ~~or the face of the track on the back of the mast to 'black band' on boom~~ to the maximum outhaul position of the clew. **Note:** where there is a stand-off track at the tack for a roller reefing main, EM shall not be measured from this stand-off point, but from the salient straight line of the main track, extended downwards.
- 6.9.3. **Mainsail Widths.** These shall be measured from sails proper, across cloth, or as per 6.13 below. Measure the perpendicular (shortest) distance from the Widthpoint on the leech to the luff. All measurements are taken at right angles to the luff and include both sail and headboard material. (See 6.2 above for details about how to make this measurement).

The following widths are the defaults assumed for mainsails. These defaults are too high for most sails and so measuring the sail will likely result in a reduced rating. If you do not have the girth measurements do not put in these numbers -- let the program make the calculation.

- | | |
|--|------------|
| 1. $\frac{1}{4}$ w - Quarter width (measured at $\frac{1}{4}$ leech) | 85% of EM |
| $\frac{1}{2}$ w - Half Width (MHW) (measured at $\frac{1}{2}$ leech) | 65% of EM |
| 2. $\frac{3}{4}$ w - Three quarter Width (MTW) (measured at $\frac{3}{4}$ leech) | 38% of EM |
| 3. $\frac{7}{8}$ w - Seven eight Width (MUW) (measured at $\frac{7}{8}$ leech) | 22% of EM |
| 4. Topw – The distance between the head point and the aft head point | 4.5% of EM |

6.9.4. Mainsail Battens may be of any length, any number and from any material.

6.9.5. **In Spar Furling** - If a yacht is fitted with a facility for In-Mast or In-Boom furling, then the appropriate tick boxes must be checked in the Spars section of the programme (which adjusts for the weight of the gear but not for any sail area loss). Battens (yes or no) and mainsail area will be assessed from the data entry in the Sails section of the programme. The correct tick boxes must be checked for each field of the data entry. There is a tick box for the type of mainsail in both the rig section of the input sheet and the mainsail section, be sure to check appropriately.

6.9.6. Schooner - The main mast is the aft mast. The fore mast is the mizzen for inputting purposes.

6.10. **Headsail Measurements** -The words **headsail** and **jib** where used below are synonymous. **LP and luff length are required minimum inputs so the measurer will have to get these measurements somehow. This typically arises when presented with a boat with a roller furling headsail that is still on the stay. This usually also occurs the day before or of last registration.....**

6.10.1. **Lp – Luff perpendicular.** Shortest distance from clew to luff.

6.10.2. **Luff – Luff length.** This will normally be shorter than the permanent forestay, but if a sail is fitted to a bowsprit or similar extension the luff may be longer than the forestay.

6.10.3. **Headsail widths** - These shall be measured from sails proper, across cloth, or as per 6.13 below. Measure the shortest distance from Width point on the leech to luff. All measurements are taken at right angles to the luff, and include both sail and headboard material. (see 6.2 above for details about how to make this measurement). All measurements are used for area

calculations. There are defaults in the system which are too high for most sails, so measuring the sail will likely result in a lower rating.

¼ w - Quarter width (measured at ¼ leech).

½ w - Half Width (HHW) (measured at ½ leech)

¾ w - Three quarter Width (HTW) (measured at ¾ leech)

7/8 w - Seven eight Width (HUW) (measured at 7/8 leech)

Topw – The distance between head point and aft head point

6.11. Spinnaker (symmetric and asymmetric) Measurements.

- **Slu** - Luff length of a spinnaker
- **Sle** - Leech length of a spinnaker
- **Sf** - Foot length of a spinnaker
- **½ W** - Half Width of a spinnaker between luff and leech. The Half Width measurement points on luff and leech are established by folding the sail head to tack and head to clew and marking the fold points on the cloth. The measured dimension is then a straight line between these two points. **Note:** In all sail measurements care must be taken that the true cloth length is established by pulling the fabric tight and measuring in a straight line. **Note:** The Half Width measurement for mainsails and jibs is perpendicular. **The Half Width measurement for spinnakers is mid leech to mid luff.**

6.12. **Mizzens, Mizzen Staysails, Gollywoblers, etc.** These sails must be declared in the database.

6.13. Setting and Sheeting of Sails

6.13.1. A headsail must be sheeted from only one point on the sail.

6.13.2. **Tack Pennants** - No tack pennant greater than 1.00 m. may be used on a jib when set as a flying sail. A fairlead may be placed towards the outer end of a main or mizzen boom for sheeting a loose footed sail forward of the boomed sail. This fitting must not be more than 0.150 m. aft of the black band position for the clew of the boomed sail.

6.13.3. **Black Bands** – If fitted may be painted or of a tape and must be a min. of 20 mm. wide and go completely around the spar. “Black” band shall mean a band of any colour contrasting to the surface of the spar, but preferably black. The term “black band” (even when not fitted) shall be taken to mean the maximum allowable extremity of the head or clew of a sail on its fully taut position. (Note – CSA acknowledges the presence of a fitted black band for the measurement of E but does not acknowledge any such band in the measurement of P – see below). **Yawls and Ketches** – For the purpose of this rule no differentiation is made between these rig types. The term “ketch” shall also include “yawl”.

6.14. **Acceptable Sail Measurements** - Sail Dimensions supplied by a reputable sail maker or other recognized rating bodies or shown on certificates from such bodies will normally be acceptable to CSA.

6.15. **Maximum Sail Hoist** – The upper limit of hoist of any sail shall be taken as the shackle pin of the particular halyard with the halyard fully hoisted. Halyard stops are not allowed as a limit of hoist. If these are present the measurer shall assess the amount to be added to the measured halyard length to establish the maximum halyard length, which will be recorded.

7. Rig Measurements

7.1. **A very important reminder: When making any measurements involving pulling a tape up the rig, be sure to attach a retrieval line. You do not want to be the person that causes a halyard to be stuck up a mast.**

7.2. **Forestay length** – Forestay length is measured along the permanent forestay from the sheave of the highest halyard **on which a jib could be set** to the intersection of the forestay and deck. Note this is different from the way IRC and ORC measure the forestay. The simplest way to do this is to use the jib halyard. If the boat has roller furling be sure to leave any of the roller furling gear out of the measurement. Some racing boats have a well for the headstay attachment. Project across the well with a batten, spirit level or similar to get the intersection. Do the same with below deck roller furling.

- 7.3. **Dh - Drum Height** - Distance from the tack point of the roller furler drum to the point at the intersection of the forestay and deck (usually only an issue with a boat with a below deck roller furler) or where the headsail would be tacked should the drum be removed, whichever is higher.
- 7.4. **J** - The horizontal distance from the forward face of the mast to the intersection of the line of the **permanent** headstay with the deck.
- 7.5. **SPL - Spinnaker Pole Length**. The maximum overall length of the spinnaker pole from the forward face of the mast to the extremity of the spinnaker pole. This distance is measured to the outside of the jaws, not the inside of the jaws.
- 7.6. **TD - Spinnaker Tack Distance**. This is the maximum measured distance from the forward face of the mast to the point where the tack of a spinnaker can be attached. This will include any extension of the hull forward of the J position and also any bow pole, prodder or similar, in its fully extended position. **Note:** The Rating Programme may assess the effect of Tack Distance differently between asymmetrical, symmetrical spinnakers and boomed out jibs relative to their proportion of J.
- 7.7. **Mcirc - Mast Circumference** – This is the circumference of the mast measured at boom height and does not include any tracks or other obstructions.
- 7.8. **Reaching tack distance**- the distance from the forward face of the mast to the tack attachment point of a headsail set flying. The measurement is recorded with the individual sail measurements.
- 7.9. **W**: This measurement is used to determine the sheeting angle. The measurement is taken from the front of the mast to a piece of line stretched between the intersection of the forestay and deck to the aftmost sheeting location. If the boat has two sets of tracks use the measurement that gives the least angle. Input the distance. The program will calculate the angle and assign a rig factor based upon that angle. If the boat has a floating jib lead, use the most inboard attachment point for the tackle, even if it is on centreline. W is input for each headsail, use the appropriate track for that headsail. If the headsail is a headsail set flying on the bowsprit, use tack location for that headsail to attach the line back to the sheeting point.
- 7.10. **Rigging Material** - If you are unsure about rig material such as Vectran, Dyneema, PBO or carbon use the “Other Hi Modulus” tick box. Note that the forestay material is now a separate entry.
- 7.11. **Discontinuous**: If the upper shrouds do not continue to the deck but terminate at the mast and spreader end check this box.
- 7.12. **Adjustable mast jack**. Check this box if there is a hydraulic jack under the mast to tension the rig.
- 7.13. **Backstay adjustable**: check the box if it is. Some boats have two backstays that each go to the top of the mast. This is considered a backstay, not a running backstay. Typically this type of backstay is on a high tech boat and will have at least one pair of deflectors off it to support the headstay.
- 7.14. **Babystay**: check if fitted.
- 7.15. **Adjustable babystay**: IF the babystay is adjustable check this box instead of babystay
- 7.16. **Inner Forestay**: If there is a fixed inner forestay check this box. An inner forestay is farther forward than a babystay. Often this stay is used to fly either a staysail or a storm jib.

8. Other Programme Entries

- 8.1. **ICF Interior Construction Factor**. Formerly called The Interior Accommodation Factor, the online rule might still show IAF. The yacht’s ICF is assessed on a scale of five (Category 0 – 4) by the measurer. ICF is not intended to be indicative of the weight of the internal fittings, as their weight component is reflected in the flotation measurements (Freeboards and “d” measurement) described above. However, ICF is intended to reflect the complexity of the interior and the way the weight is distributed. The further the weight of the interior of the yacht is from its best location for sailing, the higher the ICF. **Note that this assessment has to be consistent, and measurers are strongly advised to refer to the database and consult with other measurers to ensure that consistency between yachts is maintained. Taking a few pictures of the interior will help considerably when consulting with the other measurers.**

Category 0– Basically empty and high-tech construction. A yacht with minimal or no regard for crew accommodation or for onboard living, as can be expected for a yacht which is solely designed for racing, particularly short races. Typical examples of yachts: Melges, Cape 30, TP 52 72s

Category 1 -This is intended to include yachts which, although cruisable with some minimal accommodation, will give the impression that they are intended for racing. Weight is kept out of the ends – the forward end of the boat will be empty of accommodation and used principally as a sail and tackle bin – living facilities are utilitarian or Spartan for the size of the yacht. This boat will have an enclosed (somewhat) head, nav station, minimal galley, some sleeping arrangements such as pipe berths. **RP 37, Farr ¼ ½ Ton- 40- 400- 45- 52, J-27-30, Racing Frers, carbon/kevlar 70s & 80s racers, Older Open / Volvo racers**

Category 2 - Production race boats (standard fast cruisers, most charter fleets) with all the equipment necessary for living aboard. Reasonable water storage is provided and there are adequate lockers for storage of stores and food. **All Beneteau First & .7 / Jeanneau Sun Fast / J-Boats / X-yachts IMX-XP-34 / Dehler 30OD-XQ-34 / from 2000 / All JPK / Pogo / Tartan 10 / Dufour 34 / Albin / Reflex / Modified Swan-Club Swan-601**

Category 3 - typical production cruising boats. These boats will have more accommodation than a 2 and might have air conditioning, heat, water maker, generator. However, there is still some consideration paid to weight distribution and building the interior reasonably light. **All Beneteau Oceanis / Jeanneau Sun Odyssey / Hallberg-Rassy / Hunter / Swan / GibSea / Centurion / Chance / Carter / Feeling / Tartan 42 / Dufour / Hanse / Bavaria / Creekmore / X-yachts (non IMX-XP-34) / Dehler (non 30OD-XQ-34) / Grand Soleil /**

A Category 4 - Yachts which are fully fitted out with all equipment and gear for long-term living aboard, built heavy for ocean cruising and with little consideration given to the weight of the internal fittings and joinery. These yachts would normally have wood panelling, large water and fuel storage, fully fitted accommodation, full galley etc. **Every other “thing”, live aboard, heavy cruiser fully equipped**

- 8.2. **Exotic Materials** – Yachts with substantial quantities of Carbon Fiber or Titanium or similar hi-tech materials used in the construction of the hull/deck, keel or rudder are considered to be constructed from exotic materials. The rating programme will assess exotics separately in (i) Hull & deck, (ii) Keel and (iii) Rudder.

Note - Kevlar, Aramid, Twaron are NOT considered Exotics for the hull, keel and rudder.

Note – Exotics in the rig – mast boom, spinnaker pole or bowsprit, fixed and running rigging – are assessed in a different portion of the rating programme.

- 8.3. **Engine and Propeller Factors.** The measurer will record whether the yacht has got an engine installed and select one of the configurations allowed in each field of the data entry screen.

Engine: Indicate in this box if there is an engine fitted. Note: If the engine temporarily does not work but everything is in place the appropriate boxes have to be ticked and the ED is still valid. When the engine is removed but the propeller and/or drive system are still in place the Engine box is ticked “no” and the Engine Distance is recorded as zero. If the engine is in place but the propeller and/or the drive shaft is removed the applicable boxes are ticked. If foul play is suspected the CM must be informed.

Drive System – Select one of the following:

- a) Shaft: - A standard shaft exiting from the hull with/without a supporting bracket
- b) Saildrive: - A saildrive installation.
- c) Retracting: - A retractable bracket and propeller.
- d) None: – This covers the case where, for example, there is an engine fitted, but the shaft has been removed.

Prop Type:

- a) Folding: - Any type of folding propeller.
- b) Feathering: - MaxProp or similar – any type of feathering propeller.
- c) 3 Blade Fixed – Any propeller with three or more fixed blades.
- d) 2 Blade Fixed: - Any two blade fixed propeller.
- e) None: - For example, when the propeller has been removed. Note that if the boat has a retracting drive system be sure to check this box no matter what style of propeller is fitted.

In Aperture: Tick this box if the propeller is within an enclosed rudder aperture

To qualify for the allowances for having an engine and propeller a yacht must be able to attain a speed under engine alone (in calm conditions) of $1.2 * \text{sq.rt.LWL}$ (in ft.) in knots. This designated speed will be shown in the database. Yachts suspected of having an engine / propeller installation unable to reach the above criteria may be asked to demonstrate that ability. If unable to do so then their rating will be invalid.

- 8.4. **Open bow thruster:** This check box was implemented starting with the 2019 Rule. For 2018 an open bow thruster was adjusted for by dropping the HF by 1. **It is imperative that all measurers go back and verify that any boats where the HF was adjusted are put back to the standard number for that model of boat.** Then check the box. Most boats should have been corrected by now but there could be a few out there that have not been measured since 2018. If the boat has a bow thruster and the last measurement is 2018 be sure to double check the assigned hull factor.
- 8.5. **Hull Date** – Is the year of build of the hull. This may be adjusted for Class Legal Boats so that they may level rate regardless of hull age. **Note** – For some original classic designs, which are completely rebuilt to a modern specification and relaunched many years after original launch, then the hull date is subject to approval of the CM.
- 8.6. **Keel Material** - The measurer shall select one of the following: (from titanium, uranium etc.) or
 - 8.6.1. **Keel Type:** – Shall be either Fixed, Centerboard or Canting.
 - 8.6.2. **Keel Design:** – Shall be either Straight, Bulb, Wing, or Strut and Bulb.
 - Straight:** – a keel where the keel tip is not significantly thicker than the keel root at hull joint
 - Wing:** – a straight keel with (approx. horizontal) wings attached at the tip
 - Bulb** – a keel with a club foot or a bulb – extending either forward or aft or both, of the keel fin tip - or where the keel tip is significantly thicker than the keel root at hull joint. **Note** – a combination of wing (or winglets) and bulb shall classify as a bulb
 - 8.6.3. **Keel Material:** - Choose one of the options shown. This is the material in the relatively straight portion of the keel. For a standard fin keel this is the entirety of the keel. On a high-performance high aspect ratio keel this portion is the strut. In that case the material will likely be one of the higher modulus materials such as a fabricated steel fin, forged or carbon.
 - 8.6.4. **Bulb Material:** - Choose one of the options shown. **Other will rarely be found but there have been a very few boats made with depleted uranium for a bulb material. Be sure to bring your Geiger counter and have already had any children.**
- 8.7. **Chine Factor** - Chine factor has changed over the years and it is now simply a box to check. The original intent was to give a credit to hard chine boats that are dragging the corner of the chine through the water. Now modern race boats are using chines as a performance enhancing feature. To be a chine it must have a sharp corner. The program uses the hull factor to determine if the chine will be performance enhancing or decreasing.
- 8.8. **Forestay type** - The choice is –Hanks, Lufftape (narrow high performance style), Roller Furl Foil (roughly circular in cross section), soft-strap and soft-loop. There are now carbon hanks, check soft-strap or soft-loop and make a note . Boats with roller furling (such as the Melges 24) where there is no hard foil but simply a rolling wire will be considered to have a grooved luff tape. This should be noted in the database. Soft Hanks are considered to be equivalent to a grooved luff tape in the program, this does not mean check grooved luff tape instead of soft-loop/strap.

- 8.9. **Material Choices** - Mast, Boom, Spinnaker pole, Bowsprit, Standing rigging, Backstay, Running backstay and forestay material choices are entered in the appropriate box. Use the most appropriate material listed. Forestay material is a separate entry starting in the 2018 version of the rule. This section of the input box is also where you check if there is an inner forestay or babystay. On many modern racing boats there are deflectors fitted to the backsay or the runners. Input the number of deflectors fitted under the rig factors section.
- 8.10. **Mast Head/Fractional Rig** - A rig will be considered as either Masthead or Fractional. A Fractional Rig is a rig where the headstay fitting is sufficiently below the masthead to induce forward bend in the mast. This will generally be approx. 4% of Pm or greater.
- 8.11. **Other Factors** – These are numbers allocated to various components of the rig. The rating programme will allocate a final rig factor from a cumulative effect of each item.
- 8.11.1. Cunningham: check if fitted to the mainsail
- 8.11.2. Inhaulers: check if boat is fitted with inhaulers. Usually these are a ring fitted over the jib sheet. The line around the ring is used to pull the sheet lead in. Check the box here and in the headsail measurement box. The program decides if inhaulers are effective based upon the LP of the jib. Inhaulers are only useful on headsails sheeted inboard of the shrouds.
- 8.11.3. Outhaul: Unless the clew is lashed to a fixed point on the end of the boom check the box.
- 8.11.4. Ease purchase: This is a subjective assessment of how well the boat is laid out. Does the outhaul have a generous purchase? Is the traveler laid out so it can be easily adjusted, both access to the traveler line and is the purchase adequate, etc.
- 8.11.5. Vang/kicker inhaulers, ease purchase. If no vang check 0. If it is a basic 4:1 block and tackle that would be a 1. A vang with a cascading purchase or similar will be a 2. Hydraulic or other sophisticated vang is a 3.
- 8.11.6. Rig upgrade: There are three 3 options. Standard, 1, 2. Standard is an unmodified rig. 1 is a non-standard rig, for example a custom carbon rig on a production boat but still similar proportions to the standard rig. 2 is a substantial change, for example a carbon rig considerably taller than standard.
- 8.11.7. Runner deflector pairs: the number of deflectors coming from the backstay to the mast. Deflectors are typically only seen on racing boats. Some older boats will have typical running backstays. In this case it will be 1 or 2 if there are checkstays.
- 8.11.8. **Notes** – The following is from an earlier version of the Rule but it is still a good reference. In all above factors the measurer must use their experience and common sense. Some (most) modern racing rigs will have stiff carbon masts with few stays whereas most cruising rigs will have heavy section masts with many stays – whose purpose is to hold the mast upright rather than to tune the rig underway. Equally older (but less efficient rigs) may bend considerably more than some modern very efficient rigs. The purpose of the rig factor is to assess the efficiency of the rig as a whole to respond and adjust to variations in wind and sea conditions. Racing type rigs will score generally higher points on each factor than their cruiser counterparts regardless of the actual number and type of specific stays or adjustments.
- 8.12. **Hull, Keel and Rudder Factors Hf, Kf, Rf** - These are assessed factors scored on an open ended scale. The intention is to rank the hull, keel, rudder, in terms of their speed potential. There are both quantitative and qualitative aspects to this ranking. The intention is to assess, and to rank, the efficiency of a hull and its foils to drive the boat – both upwind and downwind – through a variety of wind and sea conditions. These factors are normally all the same (i.e. all are 7 or all are 8 etc.). Only when there are changes to the yacht's hull, keel or rudder should the applicable factor be changed. These may be increased by one or more, depending on the speed potential of the change.

Some hulls may visually appear to be fast but simply are not, and vice versa then some alteration may be made but only with the agreement of the CM. Some boats have different keel options. Be sure to determine which style keel the boat has. If the boat has a higher performance keel that is still a production option for that boat it may be necessary to assign a keel factor higher than the hull. Be sure to consult with the CM and the group for that kind of decision. As always make a note in the measurers' portion of the certificate to support the decision to assign a different KF.

The measurer MUST check the database for any sistership before allocating these factors to the boat they are measuring. If the measurer feels strongly that the database number is in error, they must raise this with the CM before altering the previously allocated Hf, Rf and Kf – which will then be altered similarly for all identical sisterships in the database.

Stanchions Outboard - Yachts with fitted stanchions angling outboard so that when a plumb bob is dropped from the lower lifeline it falls outside the salient line of the hull will incur this rating adjustment factor. The lower lifeline must be taught when making this measurement. This box is also ticked if any of the following apply: **lower lifeline out of sheer AND/or hiking straps AND/or no stanchion, no lifelines**

8.13.

8.14. **Other Programme Entries** - There may be other programme entries which are required for the database but which are not referred to in this document for reasons of brevity, redundancy, etc.

9. **Bareboat certificates** - bareboat certificates are unique in that **not the boat name but the design designates the rating**. This means that whatever boat name is on the certificate is irrelevant (to its rating) and it means also that boats with the same design name are 100% identical. Any similar boat with a different LP or keel or any other difference will have their own design name.

Check to see if the boat or type of boat exists as a bareboat in the system. The boat types are often printed on their maker's plate - usually fixed in the cockpit.

- 9.1. **Updates** - If the boat name is in the database, update it as usual for the new year - but be careful, sometimes bareboat names are re-used and you must double check it is the right boat. This is especially relevant after a major hurricane..... Charter fleets typically rotate the boats out around the five year age point so checking the hull date is useful in this situation.
- 9.2. **Fleet Change** - If an existing bareboat has changed fleets, (i.e. Moorings to Footloose), just check the LP and do an update with the new owner indicated. Also give the boat a general check over to confirm the types of equipment etc. have not changed.
- 9.3. **If none of that Type are in the database** - If there are no boats of that type, or less than three of that type, named "REFERENCE BOATNAME" then do a complete measurement, name the boat "REFERENCE BOATNAME" and contact the chief measurer.
- 9.4. If there are 3 or more boats called "REFERENCE BOATNAME" in the system but not from the same fleet, then just check the overhangs, PM, EM, LP and Forestay length. If the overhangs are close enough to the standard, or if the boat is just bow or stern down then accept the hull as standard. Create a new boat called "BOATNAME" and enter any rig or sail difference of more than 5cm.
Note: If the overhangs or any other measurement taken in 9.4 above seems way out, remeasure the whole boat and contact the Chief Measurer.
- 9.5. **Multiple Entries** - If there are 3 or more boats called "REFERENCE BOATNAME" in the system and from the same fleet, then just check the LP and create a new boat from the standard called "BOATNAME".
- 9.6. **Make General Checks** - Generally check the boat and note any unusual equipment, variations from the established standards, factors that seem to be wrong or measurements that seem inaccurate. Report any potential issues to the Chief Measurer.
- 9.7. **The draft needs to be verified with the charter company.** Usually, the boats will all be ordered the same but as the boats are privately owned it is possible that a boat will have a keel that is not the standard charter boat keel. The Moorings is supposedly now ordering all boats identically but still check.
- 9.8. **Verify the number of propeller blades.** Typically, all of the boats will have 3 blade fixed props but a few have two blades. To qualify as a bareboat the propeller must be a fixed style propeller!!
- 9.9. **Sometimes the charter companies sell the "Racing Package" as part of a charter.** As a regatta measurer it is worth checking this does not mean the headsail has been changed. The charterer will not necessarily know that is not allowed so you will have to use your best diplomatic skills when explaining to them they may not race with that headsail and the charter company must find them a

correct (both type, dacron crosscut, and LP) headsail. As a group we need to remind the charter companies of this.

9.10. Disallowed Options - Options on boats that disqualify them from getting a bareboat certificate:

- Water Ballast
- ICF 0, 1
- Prop type anything but fixed.
- Headstay anything but Roller Furling
- NO Roller drum
- Any of Mast Jack, Adjustable backstay, Runners / Checkstays, Adjustable Babystay, There are a few boats in the charter fleet that have an adjustable backstay from the factory but otherwise meet every other requirement and are in active charter fleets. In this case note it and explain it must be fixed for racing.
- Continuous Rigging
- Standing rigging anything but wire
- Backstay anything but wire
- Sail material anything but crosscut Dacron

9.11. Bareboat measurement Fees are based as follows:

- Full measurement - standard \$3 per foot + \$5 per foot
- Partial hull and rig measurement - \$3 per foot + \$50
- Create new boat on standard type - \$3 per foot + \$1 per foot with \$ 25 minimum
- Update existing boat - \$3 per foot + \$1 per foot with \$25 minimum

Figure 1:

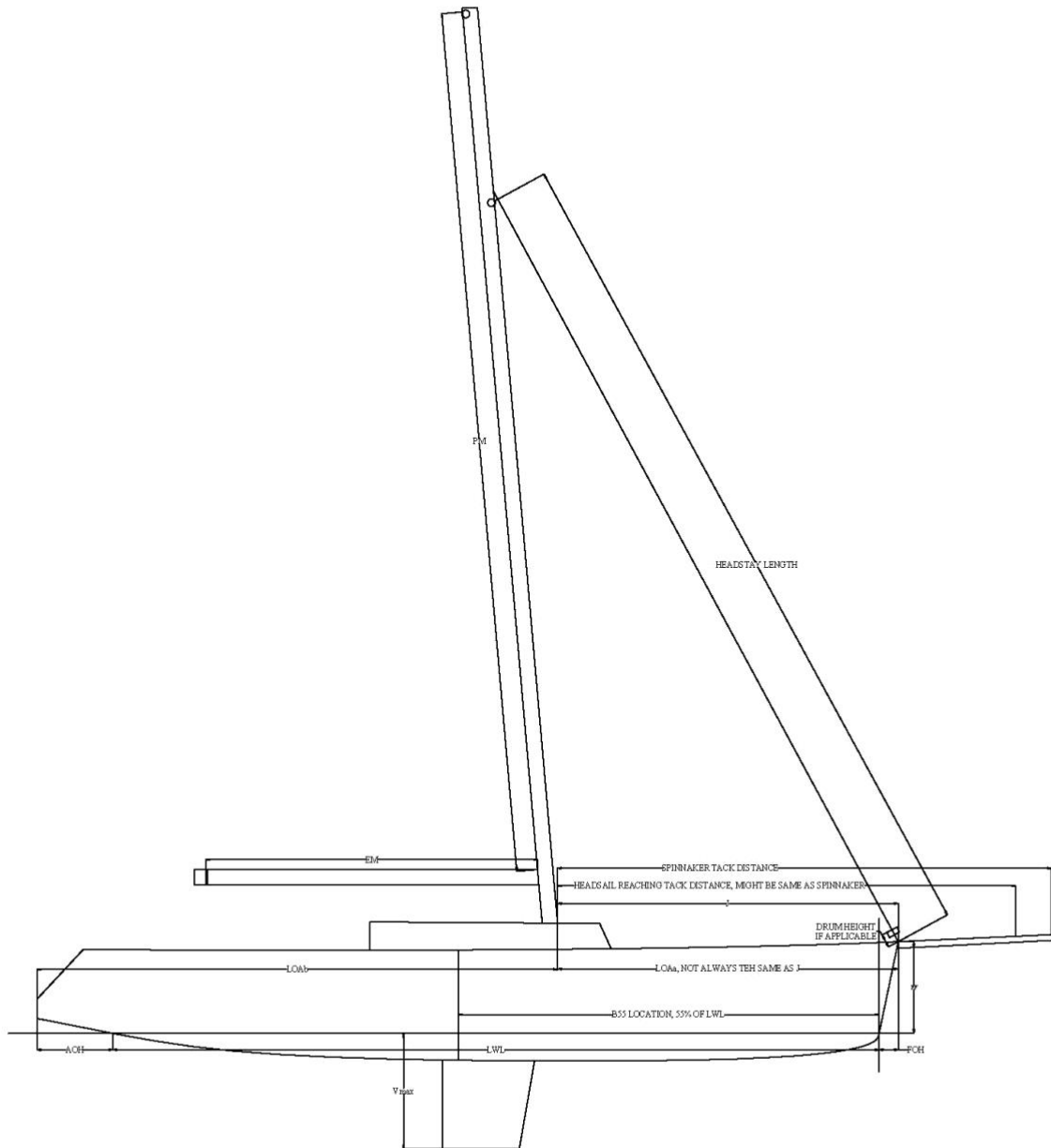

Figure 2:

B55 MEASUREMENTS

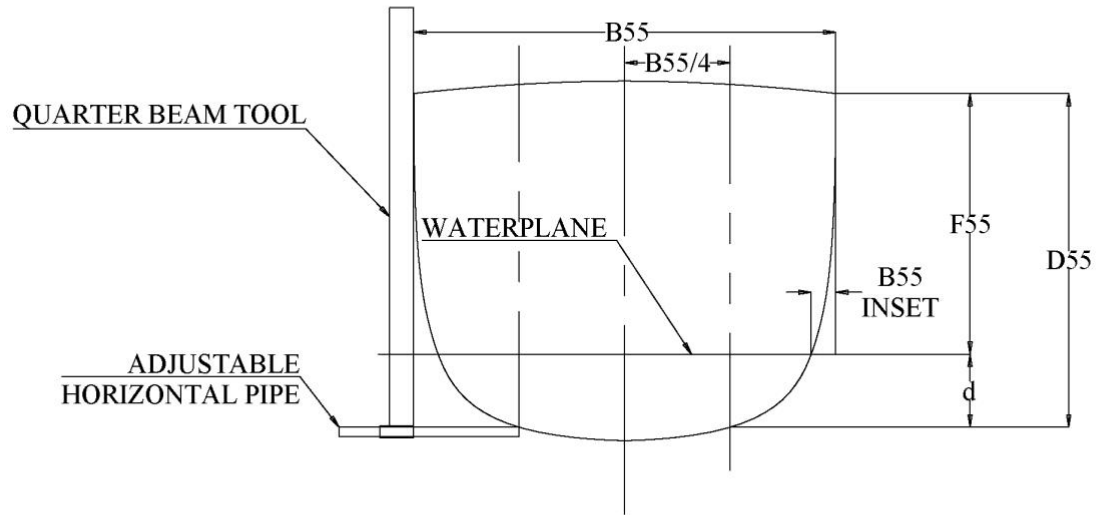

Figure 3

